



TAI-SAW TECHNOLOGY CO., LTD.

No. 3, Industrial 2nd Rd., Ping-Chen Industrial District,
Taoyuan, 324, Taiwan, R.O.C.

TEL: 886-3-4690038 FAX: 886-3-4697532

E-mail: tstsales@mail.taisaw.com Web: www.taisaw.com

Product Specifications Approval Sheet

Product Description: BAW Filter 2593 MHz Band 41 (BW 194MHz) SMD 1.1X0.9 mm

TST Part No.: TK0043AA1262

Customer Part No.: _____

Customer signature required
Company: _____
Division: _____
Approved by : _____
Date: _____

Checked by: _____ Mikey Wu *Mikey Wu*

Approved by: _____ Kazuma Lee *Kazuma Lee*

Date: _____ 2023/12/26

1. Customer signed back is required before TST can proceed with sample build and receive orders.
2. Orders received without customer signed back will be regarded as agreement on the specifications.
3. Any specifications changes must be approved upon by both parties and a new revision of specifications shall be released to reflect the changes.



TAI-SAW TECHNOLOGY CO., LTD.

No. 3, Industrial 2nd Rd., Ping-Chen Industrial District,
Taoyuan, 324, Taiwan, R.O.C.

TEL: 886-3-4690038 FAX: 886-3-4697532

E-mail: tstsales@mail.taisaw.com Web: www.taisaw.com

BAW Filter 2593 MHz Band 41 SMD 1.1x0.9 mm

MODEL NO.: TK0043AA1262

REV. NO.:1

A. MAXIMUM RATING:

1. Maximum Input Power: 33 dBm, 5000h 50 °C
2. Maximum DC Voltage: 0 V
3. Operating temperature range: -40 °C to +85 °C
5. Storage temperature range: -40 °C to +125 °C
6. Moisture Sensitivity Level: Level 3(MSL3)



Electrostatic Sensitive Device (ESD)

B. ELECTRICAL CHARACTERISTICS:

Terminating source impedance: $Z_s = 50$ (Single-ended)

Terminating load impedance: $Z_L = 50$ (Single-ended)

Item	Unit	Min.	Typ.	Max.
Center Frequency Fc	MHz	-	2593	-
Insertion Loss (2496 ~ 2500 MHz)	dB	-	2.1	2.7
Insertion Loss (2500 ~ 2535 MHz)	dB	-	1.9	2.6
Insertion Loss (2535 ~ 2675 MHz)	dB	-	1.2	1.6
Insertion Loss (2675 ~ 2690 MHz)	dB	-	1.4	1.6
Amplitude Ripple (2496 ~ 2690 MHz)	dB _{p-p}	-	-	1.7
VSWR @input port (2496 ~ 2690 MHz)	-	-	1.6	1.8
VSWR @output port (2496 ~ 2690 MHz)	-	-	1.6	1.8
Attenuation (reference level from 0 dB)				
300 ~ 925 MHz	dB	33	35	-
1565 ~ 1980 MHz	dB	30	31	-
2110 ~ 2170 MHz	dB	30	32	-

2300 ~ 2400 MHz	dB	32	35	-
2402 ~ 2422 MHz	dB	32	34	-
2407~ 2427 MHz	dB	32	34	-
2412~ 2432 MHz	dB	32	33	-
2417 ~ 2447 MHz	dB	30	33	-
2432 ~ 2452 MHz	dB	30	33	-
2442 ~ 2462 MHz	dB	30	35	-
2447 ~ 2467 MHz	dB	8	30	-
2452 ~ 2472 MHz	dB	4	25	-
2457 ~ 2477 MHz	dB	2	15	-
2462 ~ 2482 MHz	dB	1.5	8	-
3300 ~ 3800 MHz	dB	30	38	-
3800 ~ 4200 MHz	dB	30	40	-
4400 ~ 5000 MHz	dB	35	46	-
4992 ~ 5380 MHz	dB	38	48	-
5150 ~ 5850 MHz	dB	38	48	-
7488 ~ 8070 MHz	dB	25	33	-

C. OUTLINE DRAWING:

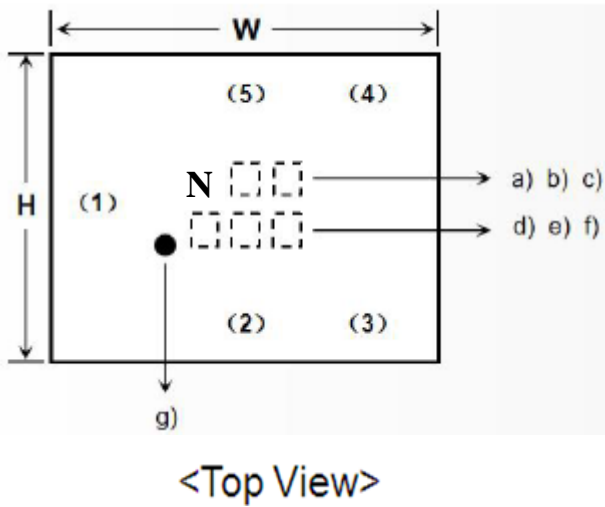

Symbol	DIMENSION REQUIREMENT	
W	1.1±0.05	Top View
H	0.9±0.05	
T	0.6 Max	Side View
A	0.2±0.03	Bottom View
B	0.25±0.03	
D	0.25±0.03	
E	0.375±0.03	
F	0.375±0.03	
L1	0.075	
L2	0.075	

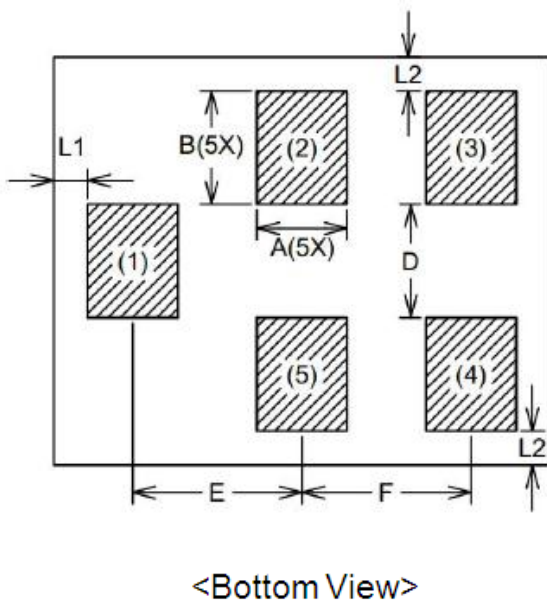
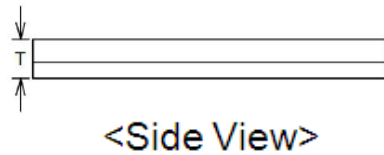

Pin No.↴	Function↴
1↴	Input↴
2↴	Ground↴
3↴	Ground↴
4↴	Output↴
5↴	Ground↴

Symbol	Description
a	Means the frequency band. The band "N41" corresponding character is "N".
b	Coding of the product information.
c	Meaning of the production types.
d	Coding of the year and month number.
e	Coding of the week number.
f	Coding of the serial number of the lot in each week.
g	Marking for pad number 1.

d) Date Code Table.

	Jan.	Feb.	Mar.	Apr.	May.	Jun.	Jul.	Aug.	Sep.	Oct.	Nov.	Dec.
2020/2024	A	B	C	<u>D</u>	E	F	G	H	J	K	L	M
2021/2025	N	P	Q	R	S	T	U	V	W	X	Y	Z
2022/2026	a	b	<u>c</u>	d	e	<u>f</u>	h	<u>l</u>	j	<u>k</u>	<u>z</u>	<u>m</u>
2023/2027	<u>n</u>	3	q	r	4	t	<u>u</u>	5	6	7	y	9

e) Week sequence of the lot ID

W1	W2	W3	W4	W5	W6
A	B	C	<u>D</u>	E	F

f) Week Code Table & Lot Code Table.

001	002	003	004	005	006	007	008	009	010	011	012
A	B	C	<u>D</u>	E	F	G	H	J	K	L	M
013	014	015	016	017	018	019	020	021	022	023	024
N	P	Q	R	S	T	U	V	W	X	Y	Z
025	026	027	028	029	030	031	032	033	034	035	036
a	b	<u>c</u>	d	e	<u>f</u>	h	<u>l</u>	j	<u>k</u>	<u>z</u>	<u>m</u>
037	038	039	040	041	042	043	044	045	046	047	048
<u>n</u>	3	q	r	4	t	<u>u</u>	5	6	7	y	9

F. PCB Footprint:

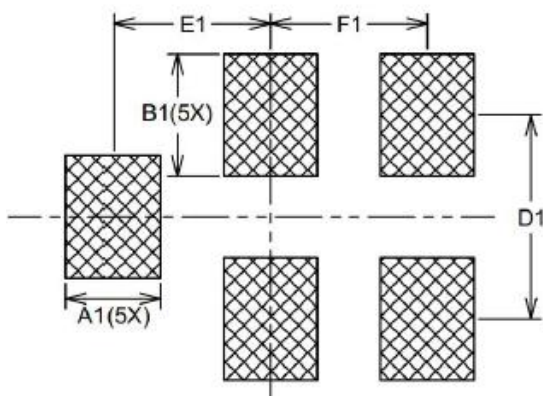

Symbol	DIMENSION REQUIREMENT	
A1	0.23±0.03	Land pattern THRU VIEW
B1	0.3±0.03	
D1	0.5±0.03	
E1	0.385±0.03	
F1	0.385±0.03	

Notes:

- 1.Dimension: mm
- 2.Dimensions nominal unless otherwise noted
- 3.Pad(1) to (5) are same size

D. MEASUREMENT CIRCUIT:

Input terminating impedance

$Z_{in} = 50 \Omega$

Output terminating impedance

$Z_{out} = 50 \Omega$

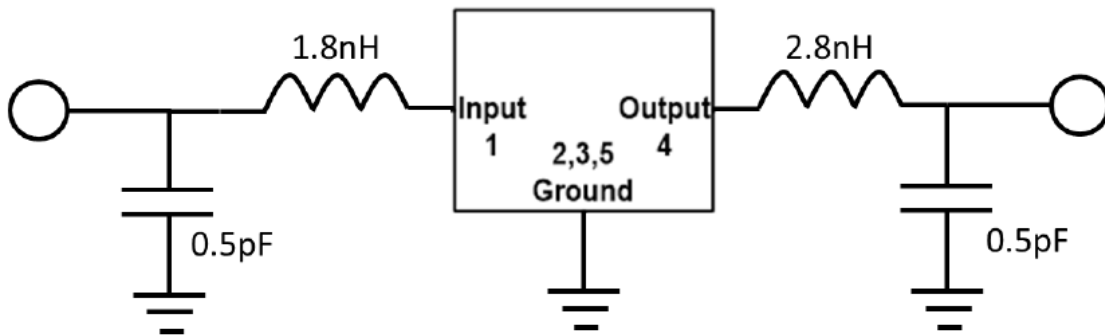

Schematic of test matching circuit

F. Frequency Characteristics:

Span 350 MHz

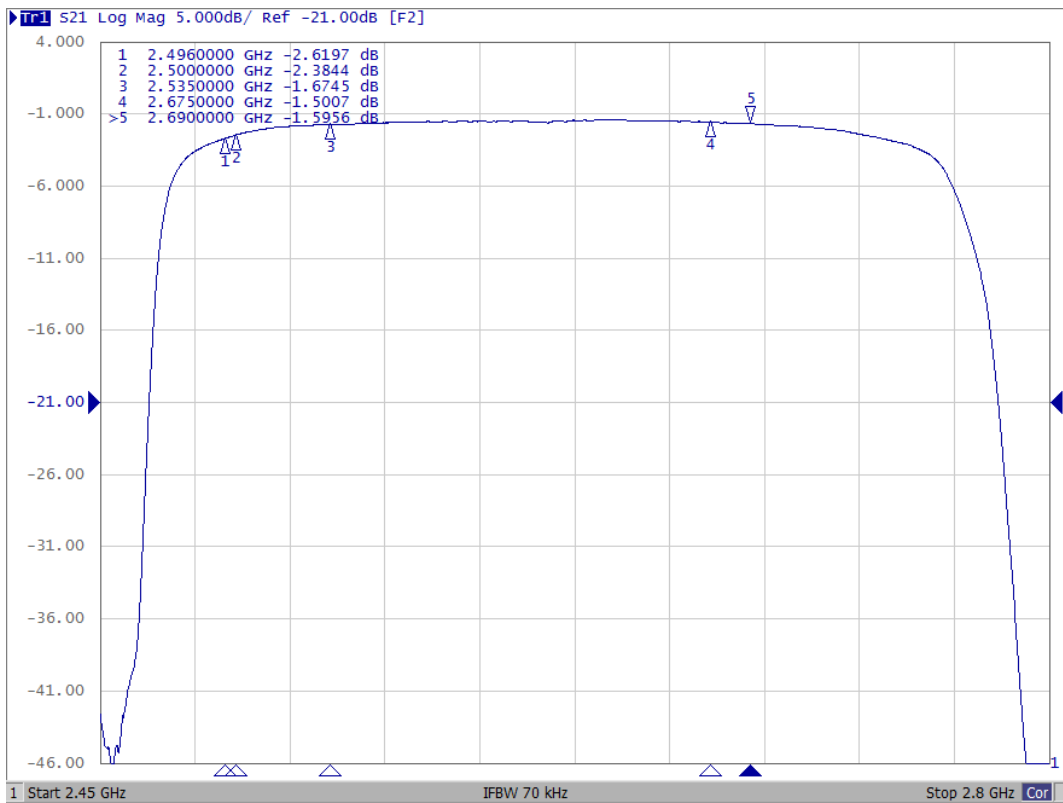

Span 1000 MHz



Span 8000 MHz

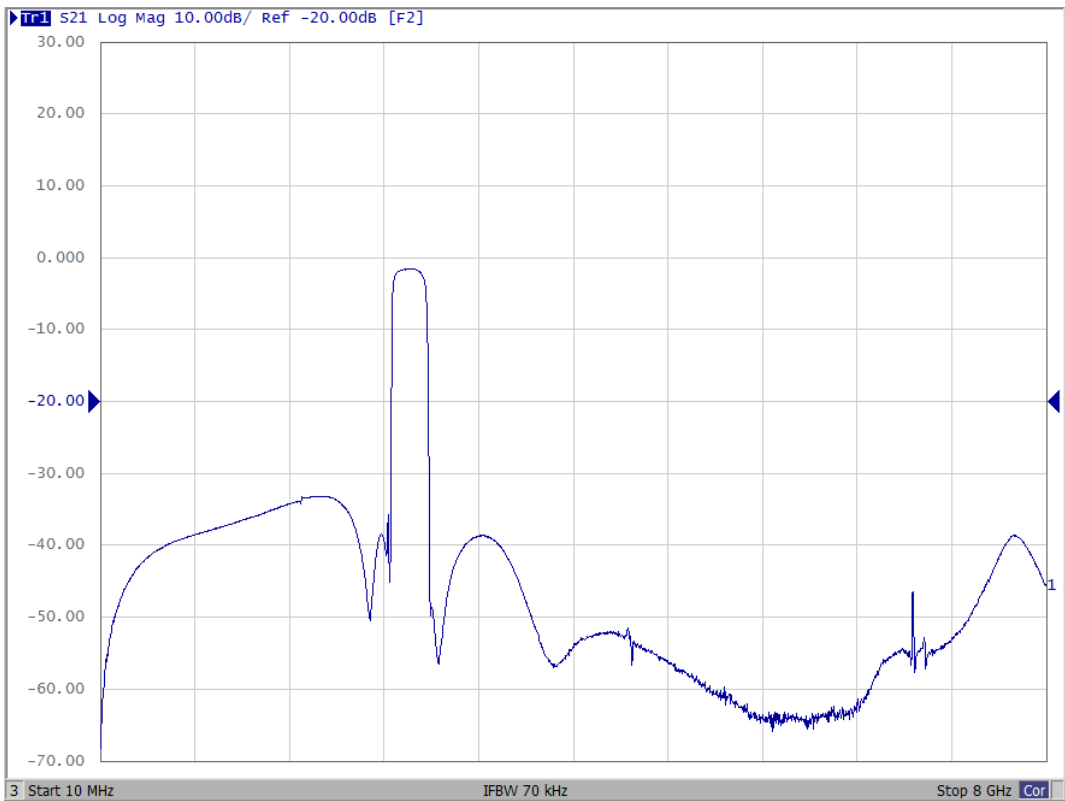

Reflection Functions:

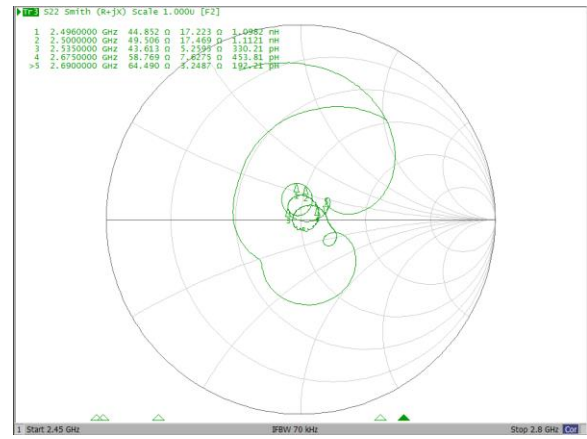
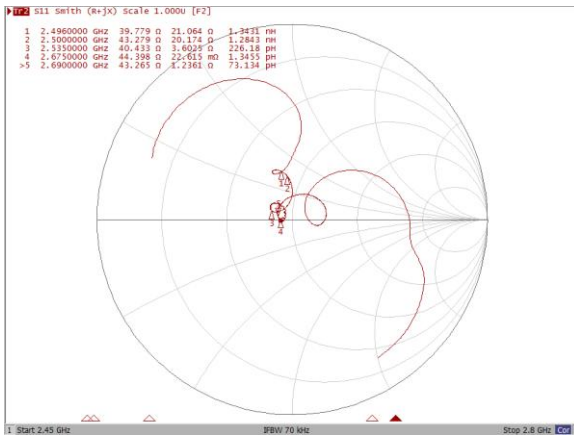
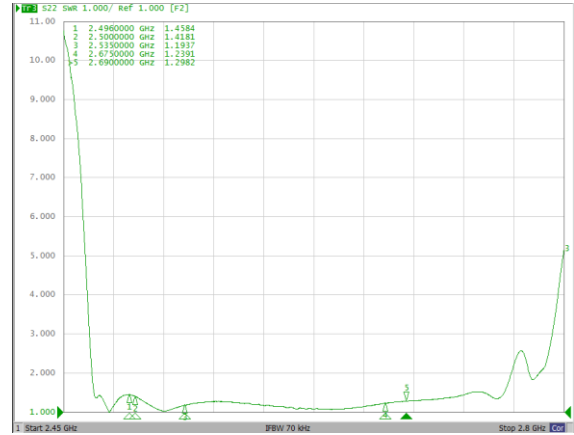
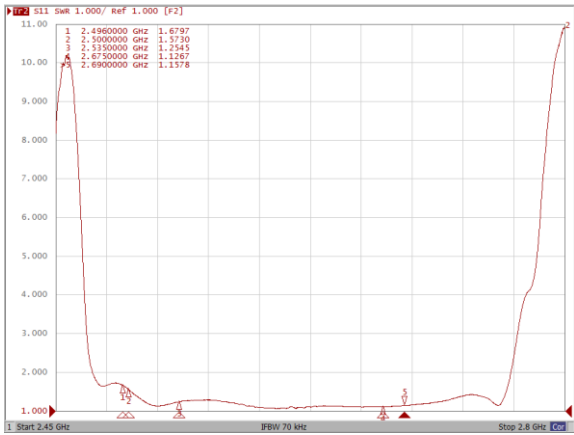

G. Packing:

(Please refer to FR-75D10 for packing quantity)

10000 pcs/reel ϕ 178mm

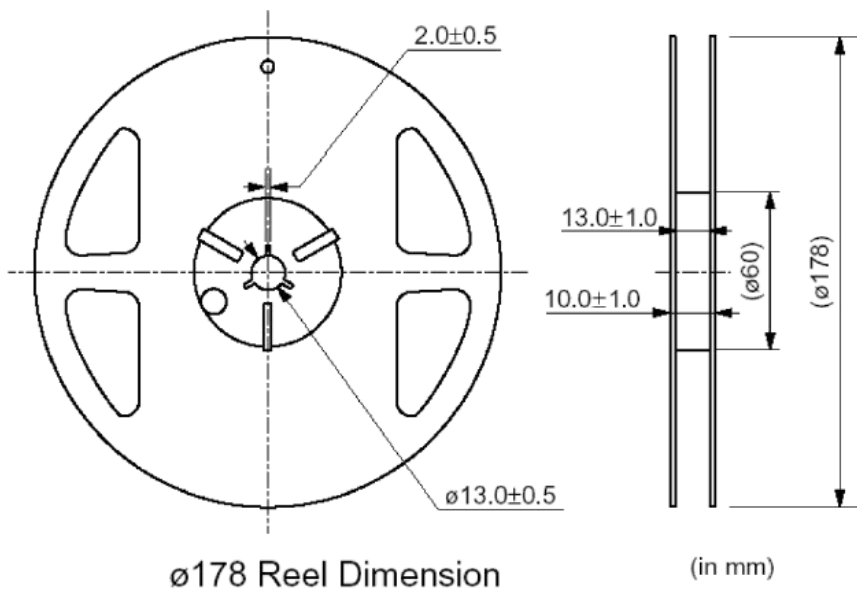

(1).Leader part and vacant position specifications

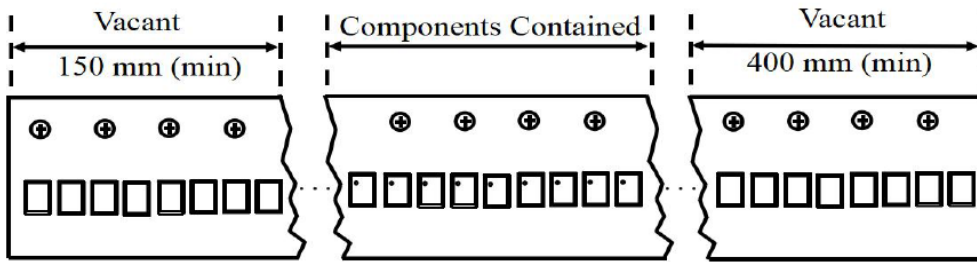

(2).Tape Specifications

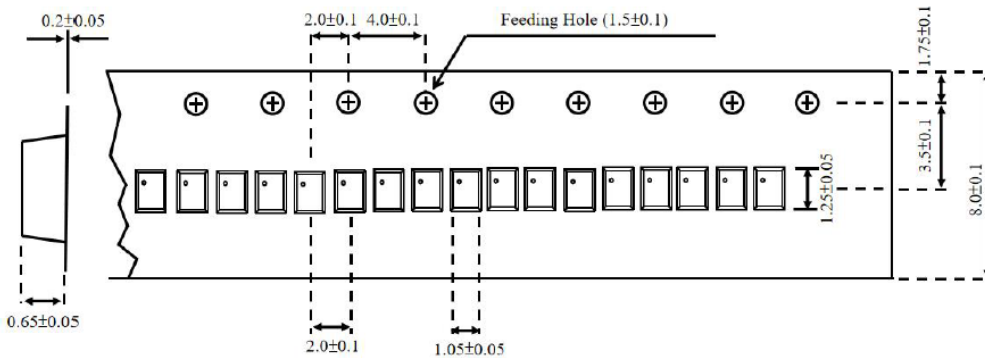

H. RECOMMENDED REFLOW PROFILE:

1. Preheating shall be fixed at 150~180°C for 60~90 seconds.
2. Ascending time to preheating temperature 150°C shall be 30 seconds min.
3. Heating shall be fixed at 220°C for 50~80 seconds and at 245~260°C peak (min. 10sec).
4. Time: 2 times.

